

Evaluation of a “walk-through” ladder top design during ladder-roof transitioning tasks



P. Simeonov^{*}, H. Hsiao, J. Powers, D. Ammons, T. Kau, D. Cantis, J. Zwiener, D. Weaver

Division of Safety Research, National Institute for Occupational Safety and Health, 1095 Willowdale Rd., Morgantown, WV 26505, USA

ARTICLE INFO

Article history:

Received 8 March 2016
Received in revised form
6 October 2016
Accepted 11 October 2016

Keywords:

Ladder
Fall
Stability

ABSTRACT

This study evaluated the effect of an extension ladder “walk-through” top design on kinetic and kinematic behaviors and the outward destabilizing forces induced on the ladder during transitioning at elevation. Thirty-two male participants performed stepping tasks between a ladder top and a roof at simulated elevation in a surround-screen virtual-reality system. The experimental conditions included a “walk-through” and a standard ladder top section supported on flat and sloped roof surfaces. Three force platforms were placed under the ladder section and in the roof to measure propulsion forces during transitions. A motion measurement system was used to record trunk kinematics. The frictional demand at the virtual ladder base was also calculated. The results indicate that under optimal ladder setup (angle 75.5 °), the frictional demand at the ladder base remains relatively small for all experimental conditions. Also, the “walk through” ladder top eased the ladder-to-roof transitions but not the roof-to-ladder transitions.

Published by Elsevier Ltd.

1. Introduction

Ladders are one of the most widely used means of access to elevated surfaces; they are simple and relatively inexpensive, but there is a persistent safety hazard involved with their use. There were 132 fatal falls from ladders for the U.S. labor force in 2010 (BLS, 2012). These incidents occurred most often (52%) in the construction industry. In addition, in 2010 there were 14,710 nonfatal injuries from ladder-related falls resulting in days away from work, 28.3% of which were in the construction industry (BLS, 2013). Extension or straight portable ladders are commonly used in construction work for variety of tasks, and frequently for access to elevated structures such as residential roofs.

Transitioning to or from a ladder at elevation was identified as one of the most dangerous activities for the ladder users (Hsiao et al., 2008). Ladder transitioning accounted for 14% of all ladder fall fatalities, in a study of OSHA detailed reports of 277 portable ladder fatalities in the period 1984 to 1998 (Shepherd et al., 2006). An earlier study of 123 occupational non-fatal ladder-falls resulting in admission to a hospital emergency room, and recorded by the National Electronic Injury Surveillance System (NEISS), found that

approximately 6% of the falls were associated with transition to or from a ladder (Cohen and Lin, 1991).

During a transition, the ladder users transfer their weight while stepping between the top of the ladder and the supporting transitioning structure, e.g., a roof surface; and thus applying forces on the ladder with a significant horizontal component. An earlier epidemiological study concluded that the horizontal force created by transitioning onto or from ladders was often the primary reason for ladders overturning or moving (Cohen and Lin, 1991). In a laboratory evaluation study on ladder transitioning, Clift et al. (2006) estimated low stability indices for tipping sideways, flipping, and losing top contact, but relatively high stability index for slide-out at the base.

Research on ladder transitioning at elevation has been relatively limited due to the associated risk of injury. To protect the participants, Clift et al. (2006) used fall protection equipment, which is not typically used with portable ladders. Recently, the innovative technology of virtual reality (VR) allowed recreating dangerous height environments in the lab (Simeonov et al., 2005) and performing fall prevention research in a controlled environment without the use of fall protection. Examples of fall prevention research using VR technology augmented with real structures include studies on scaffolding and roofing safety (Hsiao et al., 2005; Simeonov et al., 2008). The application of VR augmented with real ladder sections may be beneficial as unique novel approach for safe

^{*} Corresponding author.

E-mail address: psimeonov@cdc.gov (P. Simeonov).

evaluation of new ladder top designs and accessories during transition tasks at elevation.

Modifying the ladder top design is one suggested direction for reducing the ladder sideway-tipping risk and improving the safety of a transition task. For example, it is believed that a “walk-through” (WT) ladder top design, which can be achieved by providing handrails that extend from the ladder, will be a safer alternative and will allow for easier and safer transition. Several “walk-through” devices, attachable as accessories to the top of the ladder and providing hand-rails or hand-holds that extend from the ladder, have been proposed (Ellis, 2000; Clark and Feik, 2008; Hsiao et al., 2010; Smith, 2011), and some of them are available as products on the market.

Slipping of ladder base (slide-out) is another common cause of falls associated with the use of extension ladders (Hsiao et al., 2008). The likelihood of an extension ladder base slipping depends on factors such as, the angle of ladder inclination, the coefficient of friction between the ladder base and the supporting surface, and the magnitude and location of the static and dynamic loads on the ladder (Pesonen and Häkkinen, 1988). Earlier analytical studies have demonstrated that loads applied close to the top support of a straight or extension ladder result in the highest risk of ladder slide out (Hepburn, 1958).

While the “walk-through” design concept appears promising in reducing sideway-tipping risk, it may introduce an increased push-out force during a transition and thus an increased risk of a ladder-base slide-out. In addition, the impact of a “walk-through” design on human kinetics and kinematics as an indicator of usability has not been systematically assessed. The objective of this study was to evaluate the effect of a ladder “walk-through” top design on kinetic and kinematic behaviors and the outward destabilizing forces induced on the ladder during transitioning at elevation.

2. Method

2.1. Participants

Sixteen experienced male ladder users with average age 39.9 (S.D. = 9.4) years, average weight 87.6 kg (S.D. = 16.8 kg), and average height 184.3 cm (S.D. = 6.1 cm) and sixteen inexperienced male participants with average age 32.5 (S.D. = 12.0) years, average weight 81.6 kg (S.D. = 12.0 kg), and average height 177.9 cm (S.D. = 4.2 cm) were recruited from the Morgantown, WV area. The experienced ladder users were workers with more than one year of job-related extension ladder use and the inexperienced participants had no job-related experience with extension ladders. Potential participants with the following medical history and/or conditions were not eligible for the study: acrophobia, height vertigo, history of dizziness, neurological disorders, and abnormal and uncorrected vision. Potential participants on medications (such as, for hypertension, tranquilizers, antidepressants, antihistamines) that can impair their balance or alter their reactions, perceptions and judgments were also excluded from the study. Approval to participate was based upon successful completion of a Screening Questionnaire and an Acrophobia Questionnaire (AQ) which were administered before starting the tests. Potential participants who score more than 50 points on the AQ were disqualified for the study (even though they do not recognize themselves as acrophobic) since the average scores among individuals without a pronounced fear of heights commonly fall below 30, while average scores among acrophobic populations commonly fall above 50 or 60 (Menzies and Parker, 2001; Jackson, 2009). Potential participants not approved for the study were informed of the reasons for such a decision. All participants gave informed consent and were compensated as approved by the Institutional Review Board of

NIOSH.

2.2. Experimental setup

The study was conducted in a surround screen CAVE-type virtual reality (VR) system at the NIOSH Virtual Reality Lab. The virtual environment of elevation was augmented with a short section of a real ladder (the ladder physical model) and a real partial roof structure, which were positioned on the floor (the lower screen) of the VR system (Fig. 1 a). The VR system displayed interactive images of elevated construction site, i.e., a view over the edge of a roof. The interactive images included nearby surrounding buildings and other landscape details, as well as the virtual portion of the ladder (virtual ladder) which extended down from the floor and was supported on the virtual ground (Fig. 1b). The virtual portion of the ladder was well aligned and blended with the real section of the ladder, which extended from the floor at 75.5°, and was supported at the edge of the roof section (Fig. 1c). The roof section (1.83 × 1.83 m) had an adjustable surface equipped with pneumatic actuators, and could quickly and easily be set at 0° or 18° slope. The roof surface was completely covered by black slip-resistant material which mimicked a shingled roof. The roof edge was at 0.46 m above the floor, while the ladder section was set so that the second rung was slightly above (0.1 m) the roof edge. This setup matched the OSHA Standards - 29CFR Safety and Health Regulations for Construction subsection 1926.1053 - Ladders (OSHA, 2015) that the ladder extended at least 0.9 m above the upper landing surface to which the ladder is used to gain access.

2.3. Experimental procedure

The participants were briefed about the study objectives, methods, procedures, and potential risks. The participants then changed into tightly fitting clothes, socks, and work shoes with slip-resistant soles provided by the laboratory, to allow the accurate measurement of body movement by attached markers. Researchers attached standard spherical (14 mm) reflective markers to the

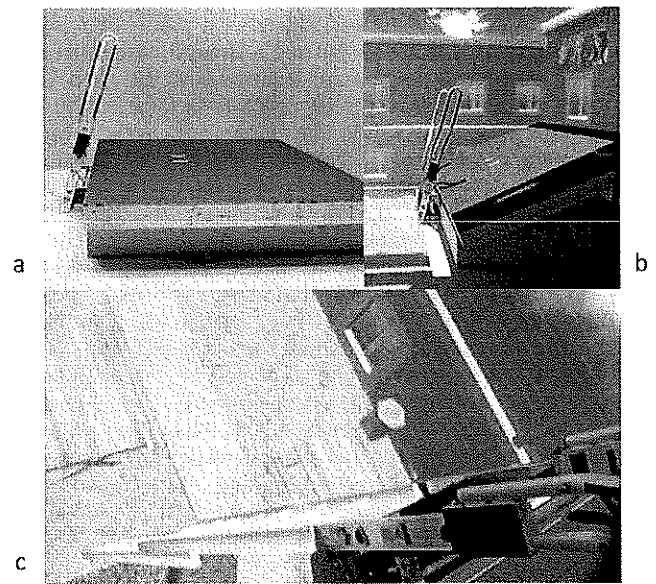

Fig. 1. Experimental setup in the Virtual Reality system. (a). Physical model of a roof and a walk-through ladder top – in the CAVE VR system; (b). Sloped roof integrated in a virtual environment; (c). View over the edge of a two-story roof at the “hybrid” real-virtual model of extension ladder.

participants' bodies according to the VICON Plug-in-gait marker set (VICON, Oxford Metrics Group, Oxford, UK).

For each transitioning task, the participants had to step from a ladder onto a roof or from a roof onto a ladder at simulated elevation. The experimental conditions included two ladder types (a standard ladder and a "walk-through") and two roof surfaces (flat and sloped). Before each test the researchers gave a brief demonstration of the transitioning task, climbing both up and down, for each combination of ladder type and roof surface. Following the demonstration, the participants were allowed to familiarize themselves with the virtual environment and practice the task at least once with each ladder type and roof surface condition.

For the transition "up" task, participants stood on the floor, i.e., the lower screen of the VR system, as if at height on the virtual ladder, and facing the real section of the ladder (Fig. 2 a, b). Following a "start" command, they climbed two rungs of the ladder, stepped onto the roof surface, and stopped after making two steps away from the ladder. For the transition "down" task, participants stood on the roof facing the ladder at a distance allowing them to make two steps before the transition. Following a "start" command, they approached the ladder turned around and climbed backward down until stepping with both feet on the floor. The participants were not given specific instructions on the transitioning strategy, i.e., they were allowed to move freely and select their initiating foot and stepping sequence, as well as transitioning rung or surface stepping location. This approach allowed for more natural transitioning behavior and the assessment and comparative evaluation of the most common and preferred transitioning strategies.

Each participant completed 16 ladder transitioning tasks repeated 3 times for a total of 48 trials. The 16 tasks were performed in four experimental blocks (two ladder-top designs by two roof-slope conditions). In each experimental block participants performed 4 tasks (12 trials), including two transition directions – up and down between a ladder and a roof, at two visually simulated height conditions (one and two story). The test sequence was balanced across conditions among the participants to reduce and average out any learning and fatigue effects. There were 3-min rest intervals between experimental conditions and 10-min rest intervals between each of the four experimental blocks. To further

ensure the safety of the participants, their heart rate was monitored at all times during the tests not to exceed an age-related maximum value equal to $220 - \text{age}$. All test procedures were completed in less than 2 h. Before the start and at the end of the experimental session the participants completed two balance performance tests (NHSTA, 2000) to ensure that the virtual environment exposure had no adverse effects. All participants passed the balance performance tests.

2.4. Instrumentation

2.4.1. Virtual reality system

A projection-based CAVE-type surround-screen virtual reality system (MechDyne Corporation, Marshalltown, Iowa, USA) was used to simulate the elevated conditions in this study. The VR system consists of three $3.97 \text{ m} \times 3.05 \text{ m}$ (13 ft \times 10 ft) wall screens and a 3.97 m by 3.97 m (13 ft \times 13 ft) floor screen. The projected images were generated and controlled by a personal computer with four graphic cards. The participants wore a pair of liquid crystal shutter glasses that separate the left- and the right-eye VR images that were being projected, making the images appear three-dimensional. A position tracking system tracked the head movement of the participant and the image generator continuously updated the VR environment to give the participant the correct perspective.

2.4.2. Force measurement (kinetic) system

Three force platforms (Bertec 4060-08, Bertec Corp., Columbus OH) and two force transducers (750 lb S-Type load cells, Model SSM, Interface Inc., Scottsdale, AZ) were used to collect data for forces applied to the ladder and to the transitioning roof surfaces.

There was one force plate at the ladder base, and the ladder was fixed to it with a hinge joint. There were two single axis load cells attached to the roof and the ladder at their intersection with a sliding joint. The single axis force gauges were positioned perpendicularly to the ladder rails. The other two force platforms were mounted flush with the roof surface at two positions where participants would most likely step while using the walk-through device and the control ladder (CL) (Fig. 3).

2.4.3. Motion measurement (kinematic) system

A six-camera VICON MX3 motion analysis system (VICON, Oxford Metrics Group, Oxford, UK) was used to collect data for the movement of the participant's body. The Vicon cameras were positioned at the top corners of the VR CAVE system. The accuracy of the Vicon system for this experimental setting (defined by a volume of $4 \times 4 \times 3 \text{ m}$) was within $1 \pm 1 \text{ mm}$. The high-speed VICON cameras allow for continuous measurement of movement by tracking reflective markers attached to selected body locations. The three-dimensional positions of the markers are determined in real-time for viewing and processing and the data is saved to a file for analysis at data collection frequency of 100 Hz.

One marker, attached to the surface of the T10 thoracic spinous process was used to track the position of the participant's trunk during the transitioning. The marker is close to the trunk center of mass (which is roughly half of the body mass), and may provide a good comparative measure for the highly diverse transition movements between experimental conditions. The approximate distance between the cameras and the T10 marker was between 2.5 m and 3.0 m. The motion data collection was synchronized with the force data collection.

2.4.4. Ladders

Two ladder top configurations were used and comparatively evaluated in this study. The upper section of a 7.32-m (24-ft)

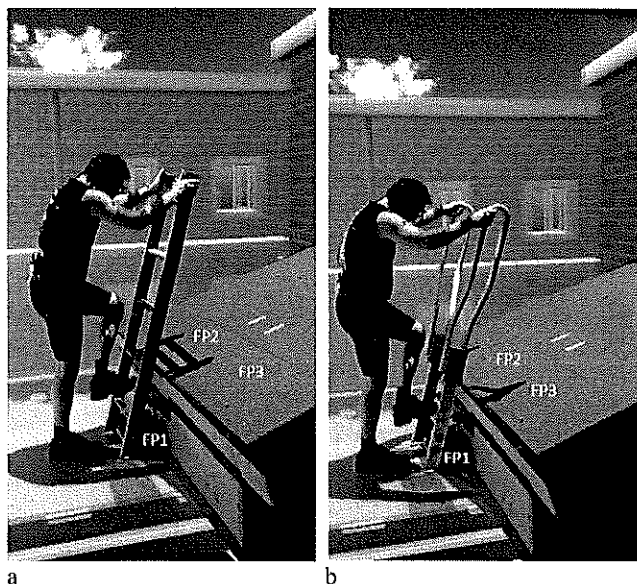

Fig. 2. Experimental procedure in the CAVE VR system, featuring transition to a sloped roof from: (a). control ladder; (b). Ladder with a walk-through top design.

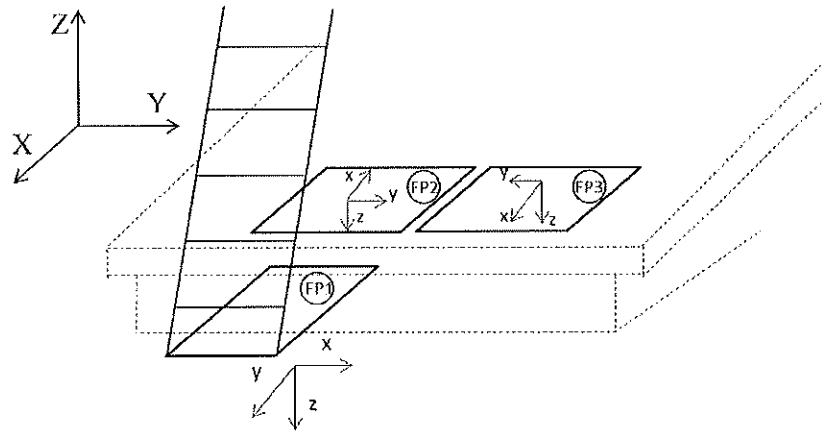

Fig. 3. Schematic representation of the force-plates setup with associated coordinate systems (small letters x, y, z). The base of the ladder section is attached to force-plate 1 (FP1), positioned on the floor (lower screen) of the VR system. Force plates 2 (FP2) and 3 (FP3) are embedded in the roof structure (sketched with dashed lines). The coordinate system on the left (capital letters X, Y, Z) represents the VICON motion measurement system.

aluminum extension ladder (Warner, D1200 Series, Type II, Werner Co., Greenville, PA) was used to make both top configurations of the ladder physical model. The control ladder used the top five-rung portion (~144 cm) of the ladder section (Fig. 2a). The walk-through design was constructed using a two-rung portion of the extension ladder upper section and a commercially available walk-through device (Safe-T, Guardian Fall Protection, Kent, WA). The walk-through device was modified and permanently attached (bolted) to the ladder section (Fig. 2b). Both the control ladder and the walk-through design extended at the same length (~107 cm) above the roof edge.

2.4.5. Roof structure

A physical model of a roof structure (roof platform) was constructed for the study and integrated within the visual environments of one- and two-story (2.80 m and 5.14 m) buildings with flat and sloped roofs. The roof platform was positioned on the floor (the lower screen) of the VR system (Fig. 1a), and aligned with the interactive images projected on the screen (Fig. 1b). The roof structure was constructed from 38 mm \times 286 mm (2 in \times 12 in) and 38 mm \times 140 mm (2 in \times 6 in) lumber and 19 mm (3/4 in) plywood and had dimensions 1.83 m \times 2.14 m (6 ft \times 7 ft) and height of 0.47 m (18.5 in). The upper part of the structure with height 165 mm (6.5 in) was hinged to the base with height 305 mm (12 in), and could be adjusted at 4/12 (18°) slope to simulate the conditions of a sloped roof, or remain horizontal to simulate a flat roof or open-floor conditions.

2.5. Independent variables

2.5.1. Ladder top design ("Ladder") – two levels

Two types of extension ladder top designs, a standard type (served as the Control type; CL) (Fig. 2 a) and a walk-through (WT) type (Fig. 2 b) were evaluated in the study.

2.5.2. Transition roof surface ("Roof") – two levels

Level and sloped (at 18°) platforms were used to simulate a flat roof (or an open floor) (Fig. 1 a) and a sloped roof (Fig. 1 b) conditions.

2.5.3. Transition direction task ("Direction") – two levels

A "ladder-to-roof" ("Up") and "roof-to-ladder" ("Down") transition tasks were evaluated. The participants performed stepping

tasks as if they are transitioning from a ladder to a roof or from a roof to a ladder, at simulated elevated conditions in the VR system.

2.5.4. Simulated height ("Height")

Two elevated conditions were visually simulated in the VR system to represent transitioning surfaces on a one- and two-story (2.80 m and 5.14 m) commercial or residential roof. This variable could help to determine the level of any psycho-physiological effects on participants' performance. Transition tasks at height are potentially dangerous in real work conditions. Using the VR simulation allowed participants to safely test the ladder top designs. Previous research demonstrated that virtual models of elevation provide slightly reduced but realistic height-distance perceptions, corresponding anxiety and danger perceptions, and comparable postural instability effects as real elevated environments, and are an effective approach for occupational safety research (Simeonov et al., 2005).

2.5.5. Work experience ("Experience") – two levels (groups)

Experienced ladder users and inexperienced participants were tested in the study. We hypothesized that the experienced group would induce less destabilizing forces than the inexperienced group when they use the standard ladder. We also hypothesized that there is no difference on destabilizing forces during transitions between the experienced workers and the inexperienced participants when they use the walk-through top design.

2.6. Dependent variables

2.6.1. Kinetic variables

2.6.1.1. Definition of transition period. For the purposes of this analysis and calculating the dependent variables, the transition period was considered as the period in which the load (from the study participant's weight) is being transferred from the one supporting structure to the other (i.e., between the ladder and the roof). The start of a transition period (loading) was defined by the time at which the receiving (ending) force platform registers for the first time a normal force (force along the z -axis) $>$ 50 N, resulting from contact with the leading foot. The end of the load transfer period (unloading) is defined by the time at which the originating (starting) force platform registers for the first time a normal force $<$ 50 N, resulting from the lifting of the trailing foot, Fig. 4 and Fig. 5 display examples of two different transitions and the

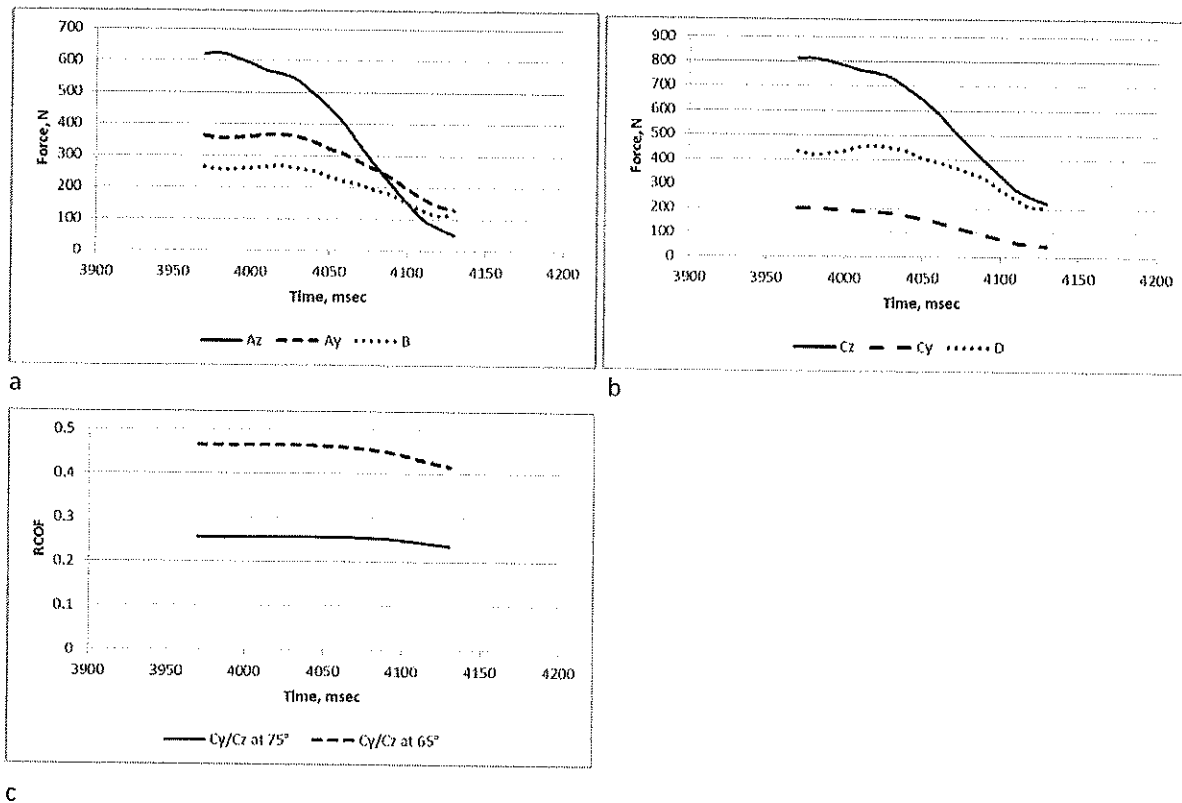

Fig. 4. Transitioning from a walk-through ladder to a two-story sloped roof (Transition Time = 170 msec); a). Reaction Forces measured from the ladder physical model; b). Estimated Reaction Forces for the virtual ladder; c). Estimated Friction Requirements at the base of the virtual ladder for setup angles of 75° ($RCOF_{avr} = 0.253$; $RCOF_{max} = 0.258$) and 65° ($RCOF_{avr} = 0.454$; $RCOF_{max} = 0.465$).

associated values of measured and estimated reaction forces and derived variables.

2.6.1.2. Required coefficient of friction ($RCOF_{max}$). The required coefficient of friction (RCOF) variable (Figs. 4c and 5c), representing the frictional demand at the base of the virtual ladder, was estimated using the equivalent load method (described below) under several assumptions. The reaction forces (A_x , A_y , and M), measured from the ladder model in this study (Figs. 4a and 5a) were used with the schematic diagram on Fig. 6, to calculate an equivalent loading (F_x , F_y , and M) at the top of the ladder. The equivalent loading was then used with the schematic diagram on Fig. 7 to calculate the reaction forces for a virtual ladder (C_y , C_z , and D) (Figs. 4b and 5b) and the corresponding RCOF (Figs. 4c and 5c) as the ratio of the horizontal (C_y) and vertical force (C_z) at the virtual ladder base. The reported $RCOF_{max}$ values were very well correlated with the average RCOF values ($RCOF_{avr}$) ($r = 0.72$, $p < 0.0001$).

The calculations were done under the assumption that all the forces during transitioning were applied to the rung next to the ladder upper support (the roof edge). For the two height conditions, the assumption was that the virtual ladder was fully extended at 6.41 m (21 ft) to access the two-story roof or partially retracted at 3.97 m (13 ft) to access the one-story roof. In addition, the assumption was that the two ladders have equal weight of 15.2 kg (149 N).

2.6.1.3. Transition time (time). The time for transition was calculated using the definition for the transition period as previously described. A longer transition time is an indicator of the difficulty of the task.

2.6.2. Kinematic variables

2.6.2.1. Transition velocity (velocity). The average transition velocity was calculated from the motion data for the T10 thoracic marker along the x-coordinate. A lower average transition velocity is an indicator of increased difficulty of a task or increased level of stress imposed on an individual.

2.7. Statistical procedure

The effects of the experimental conditions on each dependent variable was assessed using a mixed model with repeated measures analysis of variance (ANOVA). In the mixed model, the fixed effects included five independent variables (ladder, roof, direction, height, and experience) and the random effects included the correlation within each individual participant. Various models were used to find the appropriate covariance structure of observations within each participant. A model that provided the best fit was selected for final analysis. Within-participant factors included experimental conditions (ladder, roof, direction, and height) and the between-participant factor was participant's experience. For post-hoc tests in multiple comparisons, we used the Bonferroni method to adjust p-values. All analyses were performed using SAS software (SAS Institute Inc., Cary, NC, USA).

3. Results

3.1. Transitioning time (time)

Repeated measures ANOVA on the Time variable revealed significant effects of ladder, roof, and direction, as well as significant interactions of ladder \times direction and roof \times direction ($p < 0.05$) (Table 1).

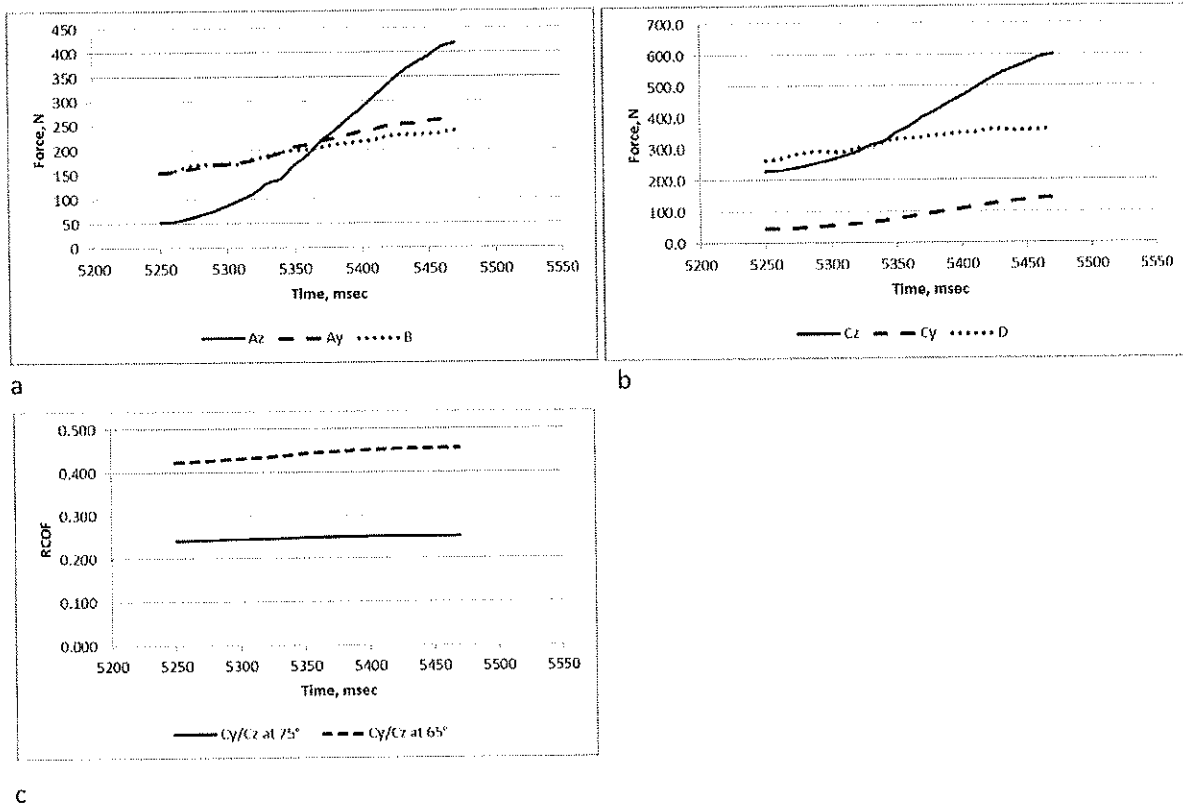

Fig. 5. Transitioning from a one-story flat roof to a control ladder (Transition Time = 230 msec). a). Reaction Forces measured from the ladder physical model; b). Estimated Reaction Forces for the virtual ladder; c). Estimated Friction Requirements at the base of the virtual ladder for setup angles of 75° (RCOF_{avr} = 0.248; RCOF_{max} = 0.251) and 65° (RCOF_{avr} = 0.442; RCOF_{max} = 0.455).

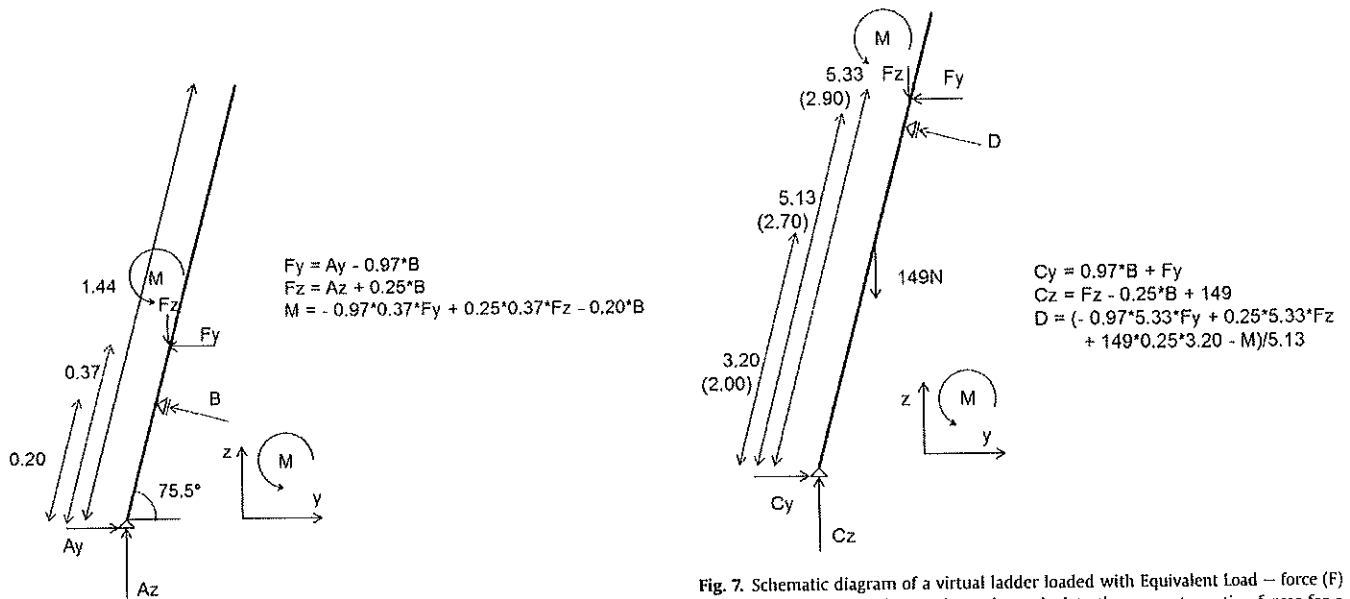

Fig. 6. Schematic diagram of the ladder physical model support and loading conditions, and calculations for Equivalent Load, i.e., force (F) and moment (M). The coordinate system on the right indicates the positive directions for forces and moment. Ay – horizontal reaction force at the base of the ladder section. Az – vertical reaction force at the base of the ladder section. B – normal reaction force at the edge of the roof structure. Fy – equivalent horizontal force at the rung next to roof edge. Fz – equivalent vertical force at the rung next to roof edge. M – equivalent moment associated with Fy and Fz.

Fig. 7. Schematic diagram of a virtual ladder loaded with Equivalent Load – force (F) and moment (M). The diagram is used to calculate the support reaction forces for a 7.32-m (24-ft) aluminum extension ladder in fully extended condition at 6.4 m (21-ft) for access to a 2-storey house roof, or retracted condition at 3.97 m (13-ft) for access to a 1-storey house roof (values in brackets). The coordinate system on the right indicates the positive directions for forces and moment. Cy – horizontal reaction force at the base of the virtual ladder. Cz – vertical reaction force at the base of the virtual ladder. D – normal reaction force at the edge of the roof. Fy – equivalent horizontal force at the rung next to roof edge. Fz – equivalent vertical force at the rung next to roof edge. M – equivalent moment associated with Fy and Fz.

Table 1
Repeated Measures ANOVA table for the dependent variables RCOF_{max}, Time, and Velocity.

Experimental Condition	Num DF	Den DF	RCOF _{max}		Time, msec		Velocity, mm/sec	
			F value	*	F value	*	F value	*
Ladder	1	30	443.98	*	11.23	*	670.32	*
Roof	1	30	4.90	*	167.14	*	72.86	*
Direction	1	30	14.85	*	252.48	*	1106.05	*
Height	1	30	781.95	*	2.87		0.12	
Experience	1	30	1.04		0.00		0.61	
Ladder*Roof	1	31	19.46	*	0.30		3.70	
Ladder*Direction	1	31	1.70		9.85	*	204.07	*
Ladder*Height	1	31	21.67	*	0.01		4.67	*
Ladder*Experience	1	30	0.02		1.27		37.45	*
Roof*Direction	1	31	2.21		12.13	*	17.74	*
Roof*Height	1	31	0.02		2.10		4.16	
Roof*Experience	1	30	0.07		1.53		2.41	
Direction*Height	1	31	3.43		0.24		0.86	
Direction*Experience	1	30	5.44	*	3.73		18.17	*
Height*Experience	1	30	0.17		0.23		0.91	

* indicates the associated p-value < 0.05.

Transitioning with the walk-through top design took 11% longer time (382 msec., SD = 325 msec.) as compared to using the control ladder (343 msec., SD = 247 msec.); sloped roof transitions required 62% more time (438 msec., SD = 342 msec.) as compared to flat roof transitions (M = 287 msec., SD = 197 msec.); and transitioning down took 69% more time (455 msec., SD = 338 msec.) than transitioning up (270 msec., SD = 189 msec.).

The significant ladder × direction interaction indicated that the major difference between the two ladder top configurations was revealed when going down – walk-through design took longer than the control ladder (493 msec., SD = 380 msec. and 418 msec., SD = 287 msec.), while there was no significant difference between the two configurations when going up (271 msec., SD = 206 msec. and 269 msec., SD = 171 msec.). The significant roof × direction interaction further revealed that the increased Time associated with transitioning down as compared to transitioning up was greater for a sloped roof (551 msec., SD = 394 msec. and 325 msec., SD = 232 msec.) as compared to a flat roof (360 msec., SD = 235 msec. and 215 msec., SD = 110 msec.).

3.2. Transitioning velocity (velocity)

Repeated measures ANOVA on the Velocity variable revealed significant effects of ladder, roof, and direction, as well as significant interactions of ladder × direction, ladder × height, ladder × experience, roof × direction, and direction × experience (p < 0.05) (Table 1).

Transitioning with the walk-through design involved 38% higher Velocity (553 mm/s, SD = 209 mm/s) as compared to the control ladder (401 mm/s, SD = 135 mm/s). Overall, sloped roof transitions were associated with 10% lower Velocity (452 mm/s, SD = 179 mm/s) as compared to flat roof transitions (502 mm/s, SD = 201 mm/s), and transitioning down involved lower Velocity (379 mm/s, SD = 132 mm/s) than transitioning up (574 mm/s, SD = 193 mm/s).

The significant ladder × direction, ladder × experience, and ladder × height interactions indicated that the increased Velocity associated with WT vs. CL was considerably greater for transitioning up (692 mm/s, SD = 158 mm/s and 413 mm/s, SD = 154 mm/s) vs. transitioning down (456 mm/s, SD = 148 mm/s and 345 mm/s, SD = 93 mm/s), for inexperienced (581 mm/s, SD = 211 mm/s and 393 mm/s, SD = 139 mm/s) vs. experienced (524 mm/s, SD = 205 mm/s and 408 mm/s, SD = 131 mm/s) ladder users, and for a one-story (560 mm/s, SD = 207 mm/s and 395 mm/s, SD = 136 mm/s) vs. two-story roof (545 mm/s, SD = 212 mm/s and 406 mm/s, SD = 135 mm/s). The significant roof × direction

interaction further indicated that the increased Velocity associated with flat-roof vs. sloped-roof transitions was larger for transition up (612 mm/s, SD = 194 mm/s and 537 mm/s, SD = 185 mm/s) vs. transition down (392 mm/s, SD = 139 mm/s and 366 mm/s, SD = 124 mm/s). The significant direction × experience interaction demonstrated that the increase in Velocity for transitioning up vs. down was greater for inexperienced (597 mm/s, SD = 209 mm/s and 377 mm/s, SD = 116 mm/s) as compared to experienced (551 mm/s, SD = 173 mm/s and 381 mm/s, SD = 146 mm/s) ladder users.

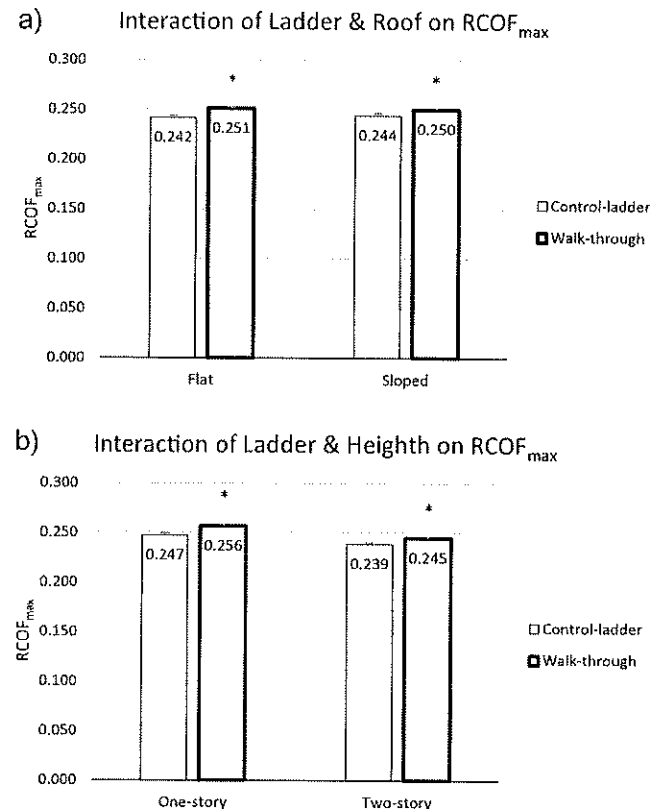

Fig. 8. a). Interaction of Ladder and Roof on RCOF_{max}. b). Interaction of Ladder and Height on RCOF_{max}. (Friction demand estimated using a statics model for a virtual ladder; error bars indicate standard error; * indicates statistically significant difference).

3.3. Maximum required coefficient of friction ($RCOF_{max}$)

Repeated measures ANOVA on the $RCOF_{max}$ variable revealed significant effects of ladder, roof, direction, and height, as well as significant interactions of ladder \times roof, ladder \times direction, ladder \times height, and direction \times experience ($p < 0.05$) (Table 1).

Transitioning with the walk-through design resulted in 3.2% higher $RCOF_{max}$ as compared to the control ladder (0.251, $SD = 0.008$ vs. 0.243, $SD = 0.010$); the differences in $RCOF_{max}$ between transitions on sloped or flat roof and in up or down direction were about 1% (0.247, $SD = 0.009$ vs. 0.246, $SD = 0.011$); and transitioning with a shorter ladder, to a one-story roof, resulted in 4.2% higher $RCOF_{max}$ as compared to transitioning with a longer ladder to a two-story roof (0.252, $SD = 0.010$ vs. 0.242, $SD = 0.007$). While all these main effects were statistically significant, the differences were practically small.

The significant ladder \times roof and ladder \times height interactions further indicated that the slight increase in $RCOF_{max}$ associated with the “walk through” ladder (WT) as compared to “control” ladder (CL) was greater for a flat roof as compared to a sloped roof (Fig. 8a), and greater for a one-story roof (partially retracted ladder) as compared to a two-story roof (fully extended ladder) (Fig. 8b). The significant direction \times experience interaction indicated that the increase in $RCOF_{max}$ associated with going up vs. going down was greater for experienced as compared to inexperienced ladder users.

4. Discussion

4.1. Effect of ladder top design

The significant main effects of Ladder indicated that transitioning with the WT ladder-top design was associated with an overall increase in all dependent variables. Specifically, when performed with the WT, the task resulted in higher transition velocity. Also, participants took longer time to complete their climbing-down transition when they used walk-through design than the control ladder, while they used the same amount of time to complete their climbing-up transition with the two ladder top configurations. This may indicate that the WT top design affords more comfortable and confident transition-movement strategies, while the CL condition is associated with more cautious transition-movement strategies. This difference also can be attributed to the movement trajectory defined by the equipment design – straight forward/backward with the WT vs. curvilinear with lateral component forward/backward movement for the CL. The curvilinear movement trajectory imposed by the CL required initial lateral displacement to clear the ladder for transition up, or final lateral displacement to align with the ladder for transition down, which modified their transition force and velocity. It took extra time for participants to figure out how to get down from the roof to the WT ladder. In addition, advancing backwards during the transition down was likely associated with more cautious movements, which could explain the overall lower values for transition velocity.

4.2. Effect roof slope and transition direction

The study results showed that, overall, transitioning down required longer time than transitioning up. However, the differences in time between the two transitioning directions were larger for the sloped roof as compared to the flat roof. In addition, transitioning down was associated with lower velocity than transitioning up and the differences between the two transitioning directions were smaller for the sloped roof as compared to the flat roof. These results suggest that transitioning down was a more

challenging task, and specifically, transitioning down from a sloped roof was the most challenging task – it was performed with slower movements, lower transition velocity, and longer transitioning time. This is consistent with earlier research indicating that standing and facing down on sloped roofs is associated with reduced postural stability (Simeonov et al., 2003); the psychological effect of stepping from a more secure stable structure onto a temporary narrow support (i.e., the ladder) may have contributed to the selection of more cautious transition strategies. The least challenging task was transitioning up to a flat roof; this task was performed with the highest transition velocities and was completed within the shortest times.

4.3. Effect of experience and ladder height

While overall transition velocity with WT is higher than CL, the differences between WT and CL were bigger for inexperienced as compared to experienced ladder users. In addition, while overall transitioning up was faster than transitioning down, the difference was larger for the inexperienced ladder users. These results may imply that the experienced ladder users were more comfortable with the WT design than the inexperienced participants.

Overall, velocity with WT was higher than with CL, but the differences between WT and CL were larger at the one-story as compared to the two-story roofs. The result may imply that under the more stressful conditions (i.e., at two-story height) the participants were more uniformly careful while transitioning and thus the Ladder effect was masked.

4.4. Some thoughts on negotiating transitions

From a biomechanics perspective, the ladder/roof transitioning (i.e., stepping over a rung, stepping over a rail, or stepping up to or down from a raised/sloped surface) can be regarded also as an obstacle negotiation task. Obstacle clearance tasks are associated with a combination of step-initiation and step-termination movement components and require simultaneous vertical and anterior-posterior control strategy (Begg et al., 1998). In this respect, the findings of this study may be interpreted as related to the perceived obstacle height, since previous research has indicated that maximum propulsive force is increased with obstacle height during obstacle clearance (Begg et al., 1998).

Furthermore, the initiation of the roof/ladder transitioning task involves a reaching and grasping component, which has been associated with specific foot-targeting phenomenon (Sparrow et al., 2003). According to this phenomenon, to ensure stability for transition initiation, the ladder user will grasp the ladder rail while using a highly consistent, optimal foot positioning strategy, in which the feet establish a posture sufficiently close to the rail for it to be comfortably grasped (Sparrow et al., 2003). The highly consistent foot positions for transition initiation will affect and determine the results for the associated transition forces.

Finally, from psychological and psycho-physiological perspective, some of the differences in the ladder/roof transitioning tasks could have been influenced by environmental factors such as the visual exposure to elevation and the associated protective fearful responses (Simeonov et al., 2005), as well as by the sloped and narrow support surfaces associated with reduced postural stability (Simeonov et al., 2003). For example, approaching and stepping next to the unprotected roof edge for transitioning down with the control ladder would be perceived as more dangerous and challenging, as compared to approaching and stepping next to the walk-through ladder, and accordingly would be associated with more cautious movements. Similarly, stepping from a stable roof surface on to the narrow rungs of a ladder will be perceived as a more

dangerous and challenging task as compared to stepping up from the ladder to the roof surface and would result in more cautious movement strategies.

4.5. Practical implications

As noted in the methods section, the modeling approach and the experimental setup in this study were designed to safely assess the loading at the top of the ladder induced by the users during ladder-to-roof and roof-to-ladder transitioning. In an effort to estimate the support conditions for the modeled ladder, the experimental results were used to calculate an equivalent loading at the top of the ladder and then derive values for the frictional demand at the virtual ladder base (RCOF). Although, these calculations were done under certain assumptions, they allowed for direct interpretation of the study results with some practical implications.

The analysis of the frictional demand variables revealed that using a WT as compared to a CL could result in small increase in the RCOF, with effects ranging from 2% to 4%, depending on the experimental conditions. Under the optimal ladder setup conditions (setup angle 75.5°) and for the 7.32-m (24-ft) aluminum extension ladder modeled in the study, the maximum frictional demand at the base of the ladder remained relatively small – in the range 0.236–0.258. In other words, under the optimal ladder setup conditions, the differences in RCOF between the two ladder top designs are not likely to cause a slide-out instability at the ladder base.

The results for maximum frictional demand during a transitioning task in this study ($RCOF_{max} < 0.258$) are similar to the results for maximum frictional demand during ladder transitioning obtained in the study by Clift et al. (2006), which were in the range 0.25–0.27. Furthermore, the $RCOF_{max}$ results in this study were even smaller than these reported for ladder climbing ($RCOF_{max} = 0.285$) (Chang et al., 2005). This suggests that although the transitioning task with a “walk-through” top design does increase frictional demand at the ladder base as compared to a regular ladder climbing task, the change is practically too small to result in a slide-out when the ladder is set at the correct angle. However, under suboptimal ladder angles, for shorter and lighter ladders, and for heavier ladder users, these effects will increase and may seriously increase the risk. For example, if the ladder was setup at a 65° angle, the $RCOF_{max}$ would approach the safety threshold values of 0.5, and the slide-out risk can be real under certain marginal slip safety conditions (Pesonen and Häkkinen, 1988), especially when the surfaces may be wet and/or contaminated with debris, sand, or grass.

With the understanding of the tested conditions and results, ladder users are reminded to follow the recommended standard practice to improve ladder safety, i.e., to secure the ladder by tying it at least at the top, and if possible both at the top and at the base (ANSI A14, 2000). In addition, use of a Ladder Safety App can help set up ladders at correct angle for improved ladder safety (Simeonov et al., 2014). Finally, the safety of the transitioning task could be further enhanced, by using a stabilizing stand-off structure or accessory that will support the ladder not on but over the wall/structure edge, roof edge or gutter, and thus improve its stability and reduce the risk of slide-out events. Alternatively, the walk-through device could be modified to include a stand-off structure and thus provide the improved ladder stability.

4.6. Limitations

This study addressed an important but difficult to evaluate ladder safety issue. The modeling and simulation experimental approach that was used, along with some thoughtful benefits (i.e.,

participant safety, controlled test environment, and the ability to use the results to assess different setup scenarios), had some limitations. The physical model of the ladder and the modified support conditions, as well as the simulated height environment in a laboratory setting, limit the range for interpretation and generalizability of the results. Alternative experimental settings, using real ladders and harnessed participants in laboratory conditions, however, have a different set of limitations as well (Clift et al., 2006).

The ladder model used in this study was attached at the roof edge, thus simulating a condition of a tied-off ladder. This may have affected participants' behavior, e.g., in some instances, some participants were leaning backwards on the ladder during the transitioning. Furthermore, the experimental setup did not allow evaluation of potential lateral instability at the ladder top, which may be greater for the standard ladder, as it requires lateral translation of the body during the transitioning process. Also, the experimental setup did not allow assessing any potential twisting or rotational instability along a vertical axis. The twisting and rotational instability may lead to backward walking at the ladder base and thus to ladder slide-out failure (Johnson, 2008). Finally, the slightly reduced distance and danger perceptions in the simulated height environment (Simeonov et al., 2005) may have also affected participants' behavior.

4.7. Suggested future research

The following are some suggested areas for research to further evaluate the walk-through ladder top design and improve the safety of ladder transitioning tasks. Ladder users tend to position extension ladders at suboptimal angles (Simeonov et al., 2012) and many workers use ladders to access steep roofs. Carrying additional loads such as from tool belts and backpacks can further interact with the ladder transition tasks. Earlier research indicated that transitioning with a standard ladder was associated with reduced stability indices for tipping sideways, flipping, and loss of top contact (Clift et al., 2006). Further evaluation of the walk-through design for these conditions is warranted. Some walk-through designs include horizontal hand grips (Ellis, 2000) and angular alignment of the device. The effects of these modifications on the ladder stability during transitioning remain to be determined. Future studies may also consider stand-off stabilizers used in combination with a walk-through ladder top design.

5. Conclusions

The results of this study suggest that while transitioning between a ladder and a roof surface with a “walk-through” ladder top design did increase the frictional demand at the ladder base as compared to the regular ladder, the difference was practically small when the ladder was set at the correct angle. The frictional demand range was also lower than the demand reported in the literature during normal ladder climbing activities (Chang et al., 2005). Therefore, use of a “walk-through” ladder top design did not demonstrate an increased risk for slide-out at the ladder base during transitioning when the ladder was set at the correct angle in our simulated work setting.

In general, the walk-through ladder design affords easier and more confident transition movements for transition up (in the terms of time and velocity measurements) as compared to the regular ladder. Challenges remain for workers to transit down from roof to ladder (in the terms of time and velocity measurements) during the use of a walk-through ladder design. Setting up ladders at the correct angle and securing the ladder by tying it at least at the top and if possible both at the top and at the base is advised. The safety of the “walk-through” top design could be further enhanced

by combining it with a stabilizing stand-off structure that will support the ladder not on but over the wall/structure edge, roof edge, or gutter, and thus improve its stability and reduce the risk of slide-out incidents, especially in the event that users set up a ladder at an incorrect angle.

Disclaimer

The findings and conclusions in this report are those of the authors and do not necessarily represent the views of the National Institute for Occupational Safety and Health. Mention of company names or products does not constitute endorsement by the National Institute for Occupational Safety and Health.

References

- ANSI A14, 2000. American National Standards for Ladders – Portable Metal – Safety Requirements. American Ladder Institute, Chicago, IL.
- Begg, R.K., Sparrow, W.A., Lythgo, N.D., 1998. Time-domain analysis of foot-ground reaction forces in negotiating obstacles. *Gait Posture* 7, 99–109.
- Bureau of Labor Statistics, 2013. National Census of Fatal Occupational Injuries in 2010: Table A-9. U.S. Department of Labor, Washington, DC. Retrieved from <http://www.bls.gov/iif/oshwc/foi/cftb0258.pdf>.
- Bureau of Labor Statistics, 2012. 2010 Survey of Occupational Injuries and Illnesses: Table R64. U.S. Department of Labor, Washington, DC. Retrieved from <http://www.bls.gov/iif/oshwc/osh/case/ostb2888.pdf>.
- Chang, C.-C., Chang, W.-R., Matz, S., 2005. The effects of straight ladder setup and usage on ground reaction forces and friction requirements during ascending and descending. *Saf. Sci.* 43, 460–483.
- Clark, B., Feik, E., 2008. Ladder Top Walk through Extensions. US Patent US7322442 B2.
- Cliff, L., Harris, D., Beasty, W., 2006. Evaluating the Stability Requirements for Mounting and Dismounting from the Top of Leaning Ladders. Research Report -178. Prepared by Loughborough University for the Health and safety Executive.
- Cohen, H.H., Lin, L., 1991. A scenario analysis of ladder fall accidents. *J. Saf. Res.* 22, 31–39.
- Ellis, N., 2000. Walk-through Ladder. US Patent US6095283 A.
- Hepburn, H.A., 1958. Portable ladders: the quarter length rule. *Br. J. Ind. Saf.* 4 (46), 155–158.
- Hsiao, H., Simeonov, P., Dotson, B., Ammons, D., Kau, T., Chiou, S., 2005. Human responses to augmented virtual scaffolding models. *Ergonomics* 48 (10), 1223–1242.
- Hsiao, H., Simeonov, P., Pizatella, T., Stout, N., McDougall, V., Weeks, J., 2008. Extension-ladder safety: solutions and knowledge gaps. *Int. J. Ind. Ergonomics* 38, 959–965.
- Hsiao, H., Zeng, S., Hsiao, J., Simeonov, P., Cantis, D., 2010. Convertible Multipurpose Ladder Stabilizers. US Patent Application 20100230208.
- Jackson, R.E., 2009. Individual differences in distance perception. *Proc. R. Soc. B* 2009 (276), 1665–1669.
- Johnson, F.M., 2008. Slips and Falls. A New Approach to Friction Measurements. Lawyers & Judges Publishing Company, Inc, Tucson, AZ.
- Menzies and Parker, 2001. The origins of height fear: an evaluation of neo-conditioning explanations. *Behav. Res. Ther.* 39 (2), 185–199.
- NHTSA, 2000. Driving while impaired (DWI) Detection and Standardized Field Sobriety Testing Student Manual. National Highway Traffic Safety Administration, Washington, DC.
- OSHA, 2015. Regulations (Standards 29 CFR) Safety and Health Regulations for Construction. Subsection 1926.1053 – Ladders. https://www.osha.gov/pls/oshweb/owadisp.show_document?p_table=STANDARDS&p_id=10839.
- Pesonen, J.P., Häkkinen, K.K., 1988. Evaluation of safety margin against slipping in a straight aluminum ladder. *Hazard Prev.* 24, 6–13.
- Shepherd, G.W., Kahler, R.J., Cross, J., 2006. Ergonomic design interventions – a case study involving portable ladders. *Ergonomics* 49 (3), 221–234.
- Simeonov, P.L., Hsiao, H., Dotson, B.W., Ammons, D.E., 2003. Control and perception of balance at elevated and sloped surfaces. *Hum. Factors* 45, 136–147.
- Simeonov, P.L., Hsiao, H., Dotson, B.W., Ammons, D.E., 2005. Height effects in real and virtual environments. *Hum. Factors* 47, 430–438.
- Simeonov, P., Hsiao, H., Kim, I.-J., Powers, J.R., Kau, T.-Y., 2012. Factors affecting extension ladder angular positioning. *Hum. Factors* 54, 334–345.
- Simeonov, P., Hsiao, H., Powers, J., Ammons, D., Amendola, A., Kau, T.Y., Cantis, D., 2008. Footwear effects on walking balance at elevation. *Ergonomics* 51 (12), 1885–1905.
- Smith, L., 2011. Fire Escape, Ladder, or Scaffold with Handrail or Guard for Ladder. US Patent application 20110247895.
- Sparrow, W.A., van der Kamp, J., Savelsbergh, G.J.P., Tirosh, O., 2003. Foot-targeting in reaching and grasping. *Gait Posture* 18, 60–68.